

*Research article*

## **Storage Solutions for Power Quality Problems in Cyprus' Electricity Distribution Network**

**Andreas Poullikkas<sup>1,2\*</sup>, Savvas Papadouris<sup>1</sup>, George Kourtis<sup>1</sup> and Ioannis Hadjipaschalis<sup>1</sup>**

<sup>1</sup> Electricity Authority of Cyprus, P.O. Box 24506, 1399 Nicosia, Cyprus

<sup>2</sup> Department of Mechanical Engineering, College of Engineering, American University of Sharjah, PO Box 26666, Sharjah, United Arab Emirates.

\* **Correspondence author:** E-mail: apoullik@eac.com.cy; Fax: +357–22–201809.

**Abstract:** In this work, a prediction of the effects of introducing energy storage systems on the network stability of the distribution network of Cyprus and a comparison in terms of cost with a traditional solution is carried out. In particular, for solving possible overvoltage problems, several scenarios of storage units' installation are used and compared with the alternative solution of extra cable connection between the node with the lowest voltage and the node with the highest voltage of the distribution network. For the comparison, a case study of a typical LV distribution feeder in the power system of Cyprus is used. The results indicated that the performance indicator of each solution depends on the type, the size and the position of installation of the storage unit. Also, as more storage units are installed the better the performance indicator and the more attractive is the investment in storage units to solve power quality problems in the distribution network. In the case where the technical requirements in voltage limitations according to distribution regulations are satisfied with one storage unit, the installation of an additional storage unit will only increase the final cost. The best solution, however, still remains the alternative solution of extra cable connection between the node with the lowest voltage and the node with the highest voltage of the distribution network, due to the lower investment costs compared to that of the storage units.

**Keywords:** batteries; distribution network; overvoltage; power quality; storage.

---

### **1. Introduction**

According to the European Union (EU) Directive 28/2009/EC [1], Cyprus as an EU Member State has an overall target that the share of energy from renewable sources in gross final consumption of energy by 2020 will be 13%. In order to accomplish this target, Cyprus has established a national

---

renewable energy action plan on how to reach this target. Based on this action plan [2], there is the need of large integration of photovoltaic (PV) systems in the distribution network.

Cyprus is an island with no indigenous hydrocarbon energy sources. This means that its power generation system operates in isolation and totally relies on imported fuels for electricity generation. Currently, the primary imported fuel used in electricity generation is heavy fuel oil with a contribution of 92% of the energy mix and the remaining 8% being gasoil. Cyprus power generation system consists of three thermal power stations with a total installed capacity of 1438 MWe. Moni power station consists of  $6 \times 30$  MWe steam turbines and  $4 \times 37.5$  MWe gas turbines. Dhekelia power station consists of  $6 \times 60$  MWe steam turbines and two 51 MWe internal combustion engines blocks. Finally, Vasilikos power station consists of  $3 \times 130$  MWe steam turbines, a 220 MWe combined cycle technology and a 38 MWe gas turbine. The steam units at Vasilikos are used for base load generation, while the steam units of Dhekelia are used for base and intermediate load generation. The steam units at Moni as well as the gas turbines are mainly used during system peak loading. All stations use HFO for the steam turbine units and the internal combustion engines blocks and gasoil for the gas turbine units. The combined cycle unit is expected to use gasoil as fuel for its first few years of operation until the arrival of natural gas in Cyprus. These power stations are owned and operated by the Electricity Authority of Cyprus (EAC), which currently is the sole producer of electricity on the island from conventional fuel. This is despite the fact that the energy market in Cyprus has been liberalized since 2004 with the establishment of the Cyprus Energy Regulatory Authority and the Cyprus Transmission System Operator. The share of renewable energy sources in electricity generation amounts to small PV systems installed in rooftops or PV parks up to 150 kWe, with a total combined grid connected capacity of approximately 6 MWe, and to biomass gasification units (the majority of which use animal or domestic waste) with a total grid connected capacity of 7 MWe. A wind park with a total combined capacity of 82 MWe is also in operation [2].

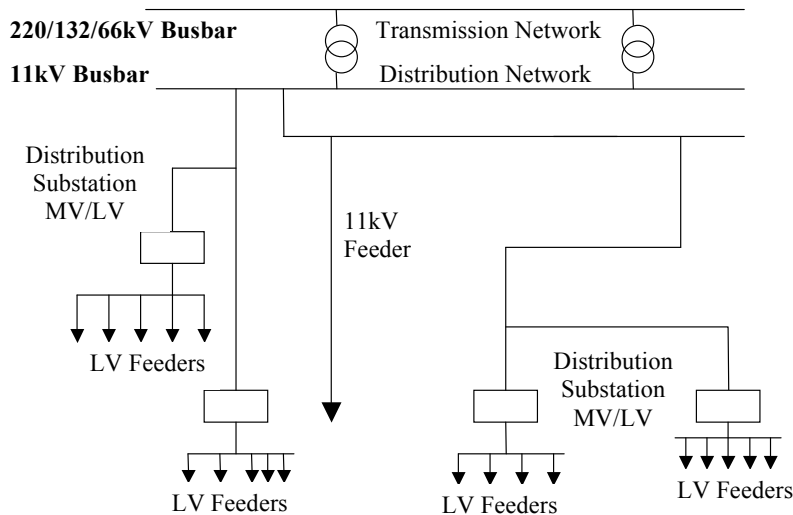
The large integration of PV systems and other distributed energy resources (DER), like small wind turbines, in the distribution network will produce a number of power quality problems, such as overloading of network components, overvoltage and undervoltage situations, voltage dips and harmonic distortion [3,4]. The network problems can be solved by using storage systems, like batteries and flywheel systems, in combination with power electronics (i.e., the use of inverters) and energy management systems [5,6,7].

In this work, a prediction of the effects of introducing energy storage systems on the network stability of the distribution network of Cyprus and a comparison of these storage systems in terms of cost with a traditional solution in the local network infrastructure is carried out. In particular, the structure of the Cyprus distribution network is described and the PLATOS software tool [5], which was used for the comparison, is presented. In order to investigate the possible overvoltage effects in the distribution network of Cyprus, on both a technical and economical point of view, several scenarios of storage units' installation are used and compared with the alternative solution of extra cable connection between the node with the lowest voltage and the node with the highest voltage of the distribution network. For the comparison, a case study of a typical low voltage (LV) distribution feeder of Cyprus is used.

In section 2, the Cyprus distribution network is described. The PLATOS software tool is presented in section 3, whereas the simulation results, which include the case study, the investigated scenarios and the input data, are provided in section 4. In section 5, the discussion of the results is provided. Finally, the conclusions are summarized in section 6.

## 2. The Cyprus Distribution Network

The power system is typically hierarchical and is divided by functional areas depending on the voltage levels. These levels, which are the transmission network, the high/middle voltage (HV/MV) substations, the MV distribution network, the MV/LV transformer substations and the LV network, are shown on Figure 1.



**Figure 1. Hierarchical structure of the electricity network.**

The distribution network in Cyprus is designed and constructed according to the international common practice and maintained to high levels of performance and efficiency. The network configuration in the urban areas is designed in ring configuration allowing interconnection between the MV feeders having multiple connections to other points of supply. Radial connection is limited to long, mainly rural lines with isolated load areas. Most of the connection points are normally open allowing supply only from one point at a time, but easily can be closed in order to provide alternative point of supply if this is needed or required due to contingency. In urban areas the MV network is usually facilitated with underground construction utilizing cables and indoor substations, while for the LV network there is a mix of overhead line construction utilizing wooden poles and wire conductors and underground construction with cables. In rural areas, the overhead constructions are employed for both the MV and the LV network. The underground substation break point switches used in ring main units of the MV network are either oil-insulated or gas-insulated and those break points of the overhead network are usually of D-Fuse type that can be connected or disconnected on-load. Air-brake isolators and auto-recloser units are increasingly installed also, in overhead arrangements. EAC is in line with all recent developments in the modern distribution network practices and tries to adopt all the new developments in the area [8].

EAC utilizes analytical software tools like DigSilent PowerFactory [9], in order to perform the design and expansion of the distribution network. The voltage drop and the loading of the conductors are among the key factors that are taken into consideration for expansion of the network [10]. Regarding the voltage drop, especially in long MV feeders in which voltage cannot be regulated using the tap changer of the transformers, EAC used to install voltage regulators. This was not considered as an effective measure, thus now EAC introduces higher MV distribution voltage (22 kV)

---

in order to reinforce the network and also reduce the losses, thus effectively eliminating the problem of voltage drop. Regarding the maximum current in conductors, EAC derives its annual network expansion based on the findings of software analysis studies, which employ actual measurements taken throughout the year from the network. Just to outline some limits regarding the current in conductors, EAC performs expansion in a region of the distribution network, when a MV feeder is loaded near to 70% of its rated capacity, when a distribution substation is loaded near the 70% of its rated capacity and when a MV feeder is connected to more than 8–10 distribution substations. The LV feeders are reinforced when they reach the 60% of their rated capacity.

EAC regularly performs power quality examinations with frequent monitoring of the supply. The observations show that the power quality of the supply in the grid is within the normal operating parameters. Since in Cyprus there is only light industry there are no serious issues on the power quality of the supply. In the unlikely event that a discrepancy occurs related to power quality issues, immediate corrective measures are taken to resolve the issues. In a number of limited cases some problems occurred related to voltage dip and voltage drop situations, which easily have been eliminated with the necessary reinforcement of the distribution grid [11]. On the other hand, in a few cases harmonics distortion has been identified in the power supply of large commercial consumers, which has been corrected with the installation of suitable power supplies [8].

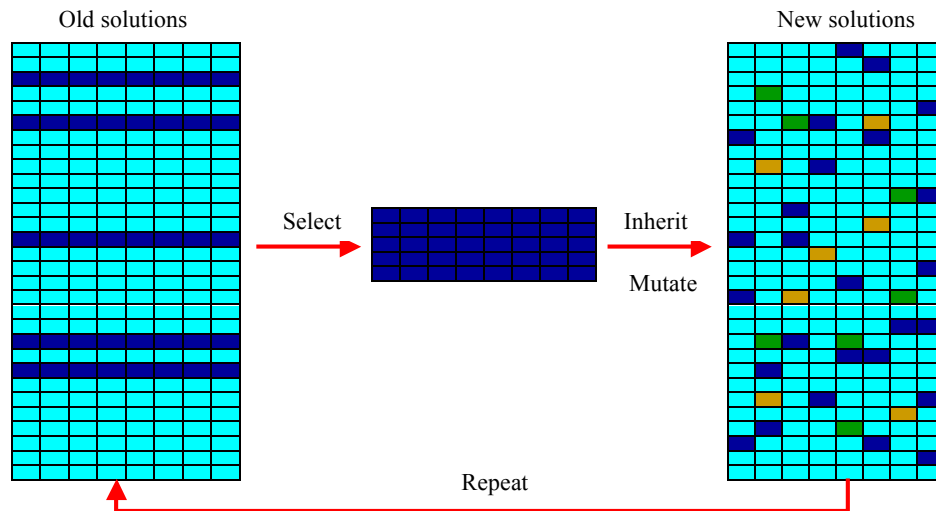
### 3. The PLATOS Software Tool

In order to predict the effects of introducing energy storage systems on the network stability of the distribution network of Cyprus and make comparisons in terms of cost with a traditional solution in the local network infrastructure, the PLATOS software tool has been used for all simulations. This tool, which was produced within the GROW-DERS project [9], is a planning tool for optimization of modular storage applications in power systems and it was programmed in DigSilent PowerFactory by using DigSilent programming language [12]. The optimization concerns the location, type and size of modular storage systems as a combinatorial problem with many possible solutions. The combinatorial problem is solved by the application of an artificial evolution, in particular using a genetic algorithm, as illustrated in Figure 2, by following the steps (a) create random solutions, (b) analyze all solutions, (c) select the best solutions, (d) create new solutions based on the best ones and (e) if the performance convergence objective is not satisfied go to step (b).

For the simulations the following input data is required, (a) load patterns, (b) component data, (c) network topology, (d) generation patterns, (e) number, location and size of fixed storage units, (f) power system components to be monitored, (g) data required for assessment of solutions, (h) number of storage systems, (i) type of storage systems, and (k) size of storage systems. Also, the solution spaces could be defined by the user with the (a) desired number of solutions to be investigated, (b) extent of each solution space, (c) optimization objectives, (d) simulation period, and (e) data required for solution assessment.

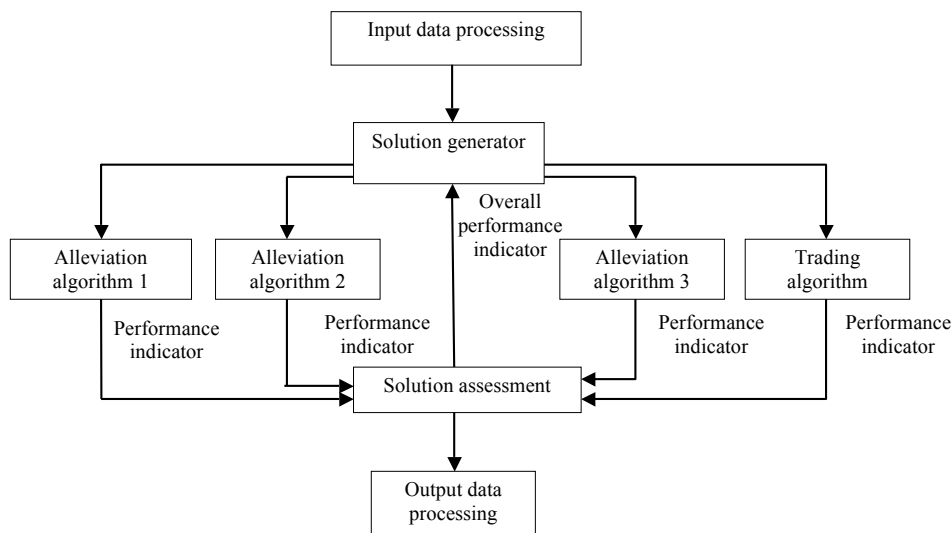
As illustrated in Figure 3, PLATOS tool automatically assesses the alternative solutions to the network problems, such as other tap changer settings, replacement of the power connections or additional power connections. The result of this assessment is used as a starting point for the assessment of the storage based solutions. Then the PLATOS automatically generate the storage solutions, which are influenced by the calculated performance indicator of the previous solutions and rejects the bad solutions (i.e., solutions that have too high investment costs, too small storage

capacity, too small and too large charging and discharging power).



**Figure 2. Genetic algorithm process.**

In the case of overload, undervoltage and/or overvoltage in a LV distribution network, the overload and voltage alleviation algorithms of the software automatically determine the overload locations and overload severity or the locations with undervoltage and/or overvoltage conditions, the required storage capacity to solve the overloading or voltage problems, the power set-points for storage inverters by taking into account operating constraints (minimum and maximum state of charge), and the performance indicator by taking into account the (a) effect of storage on overload or voltage, (b) investment costs, (c) energy losses, and (d) user storage cycles.



**Figure 3. Basic design of optimization model.**

In order for the PLATOS tool to find the optimum solution, a performance indicator is used as an objective function, which takes into account the costs and benefits of a particular solution and it is

expressed as the net present value (NPV) of the storage system, which is the value of all future cash flows discounted in today's currency. The costs include investments and operational costs, such as network losses and charging/discharging cycles. The benefits include the improvement of voltage quality, the decrease of overloading levels and the avoided claims or penalties. The results of the PLATOS software include (a) optimal locations of storage systems, (b) optimal number and type of storage systems, (c) required specifications for storage systems, (d) optimal set points for storage systems, and (e) performance indicators for each storage management algorithm [5, 13].

## 4. Simulation Results

For the investigation of the possible overvoltage effects in the distribution network of Cyprus, on both technical and economical point of view, several scenarios of storage units' installation are used and compared with the alternative solution of extra cable connection between the node with the lowest voltage and the node with the highest voltage of the distribution network [14]. For the comparison, a case study of a typical LV distribution feeder of Cyprus is used.

### 4.1. Case Study Input Data

In order to validate the PLATOS software on the effects of introducing energy storage systems on the network stability, a typical LV distribution underground (cable Al 300 mm<sup>2</sup> XLPE) feeder of the Cyprus distribution network was designed in the DigSilent PowerFactory, as shown in Figure 4. It consists of radial lines with seven nodes, general loads and two PV systems, with the first one installed in node 3 (J2) and the second one in node 7 at the end of the feeder (J6). Also, in Figure 4 are provided (a) the voltage magnitude from line to line in kV of each node, (b) the magnitude of the voltage in per unit (p.u.) of each node, (c) the angle of the voltage in degrees of each node, (d) the active power in MW of each branch, (e) the reactive power in MVar of each branch, (f) the loading in % of each branch, (g) the magnitude of the current in kA of each branch, (h) the active power in MW of the external grid, (i) the reactive power in MVar of the external grid, (k) the power factor of the external grid, (l) the active power in MW of the general load at each node, and (m) the reactive power in MVar of the general load at each node.

The magnitude of the voltage in p.u. for twenty four hours of each of the six nodes (J1–J6) of the LV distribution feeder is illustrated in Figure 5. It can be observed that some nodes have overvoltage problem between 10:00 and 15:00 hour, as the magnitude of the voltage is over the upper limit of 1.1p.u. The loading in % of the transformer 11 kV/400 V and the loading in % of the connection LS1 of the feeder for twenty-four hours are illustrated in Figure 6 and in Figure 7, respectively. It can be observed that during evening peak both experience overloading problems (over 100%). Also, the typical daily PV system load curve used in this analysis is illustrated in Figure 8.

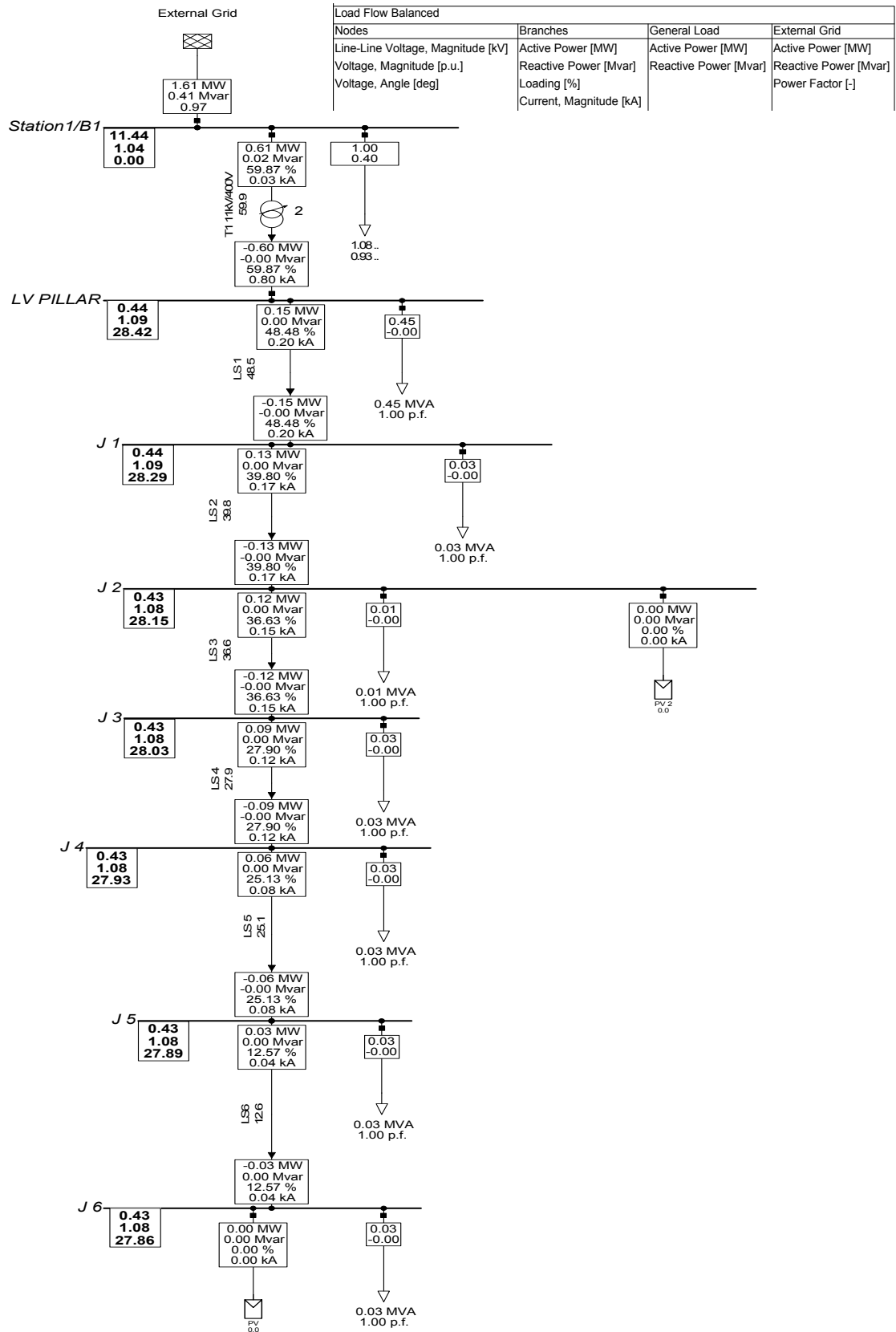


Figure 4. Typical LV distribution feeder.

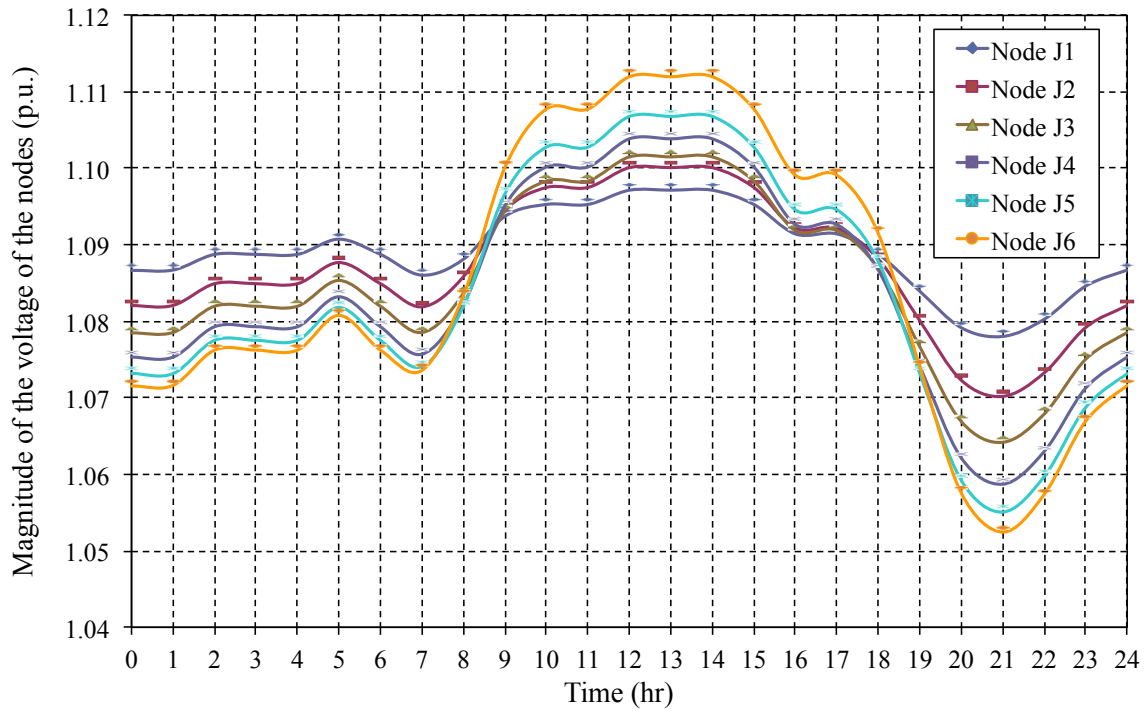


Figure 5. Daily voltage magnitude of each node.

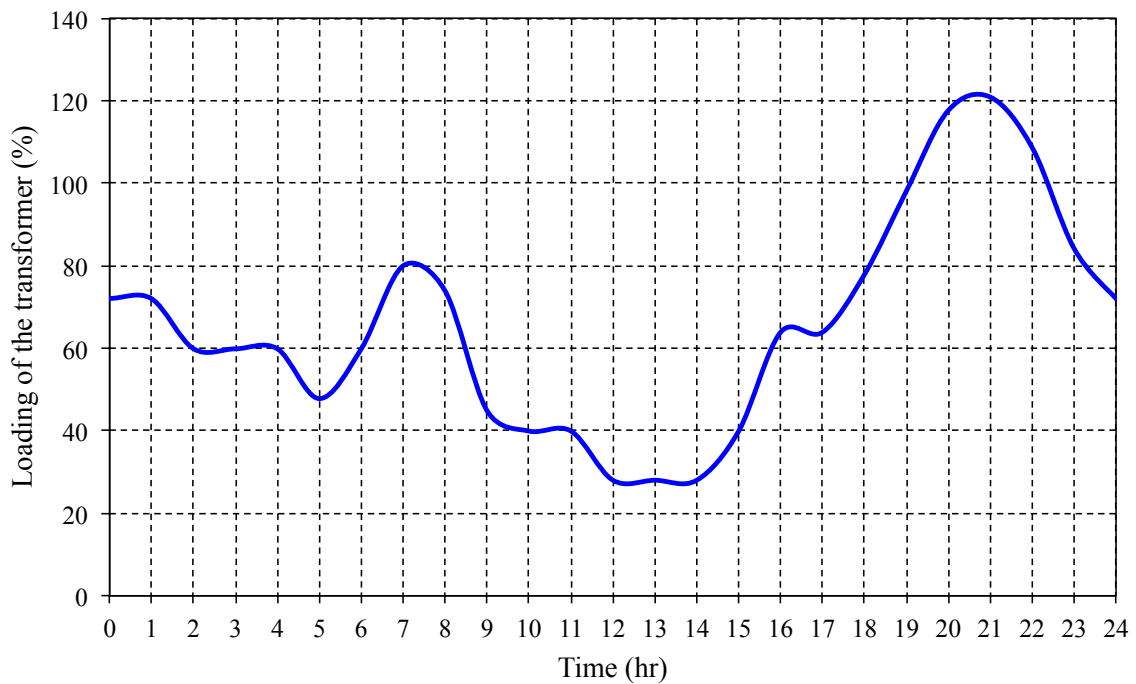
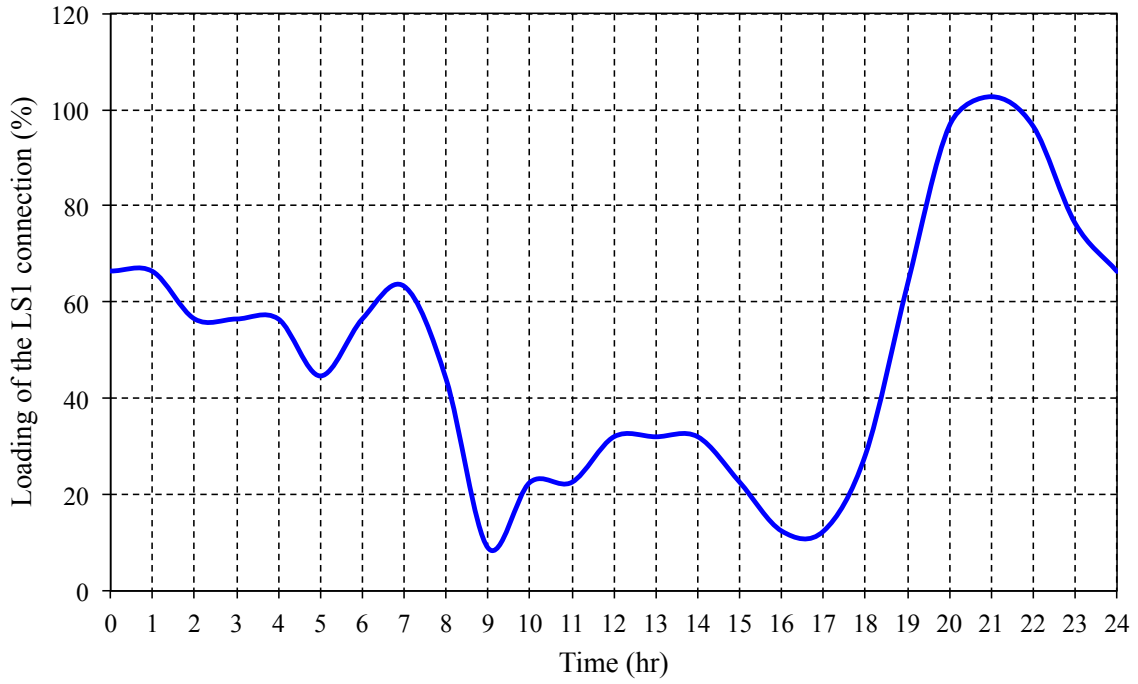
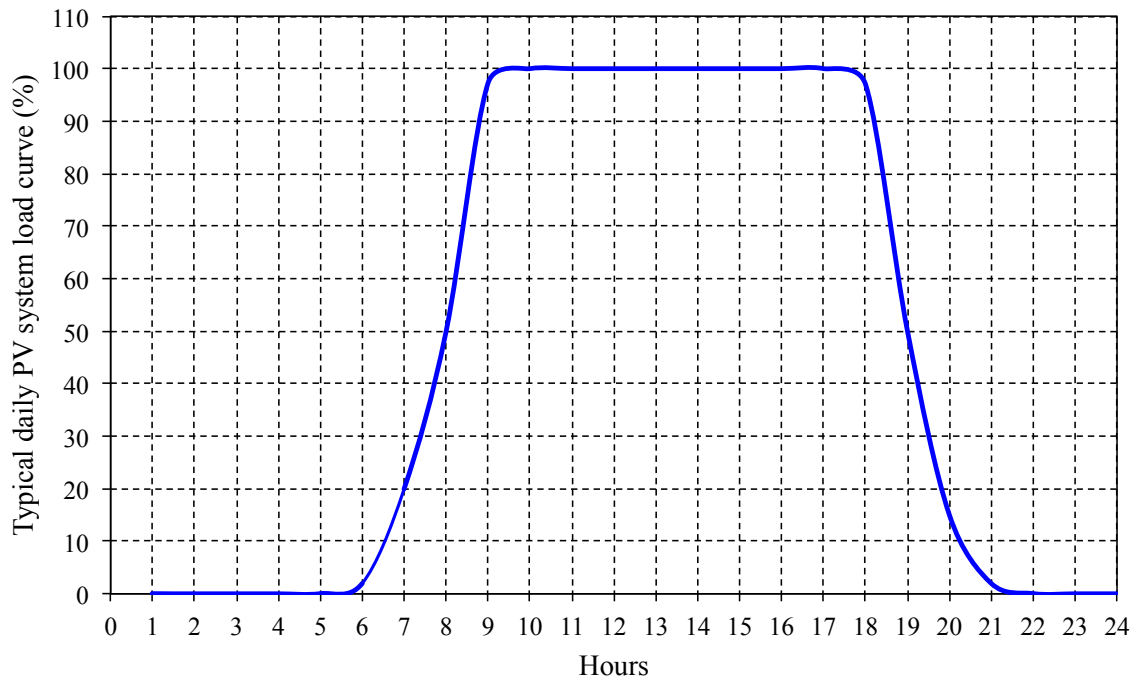


Figure 6. Daily transformer 11kV/400V loading.



**Figure 7. Daily LS1 connection loading.**



**Figure 8. Typical daily PV system load curve**

## 4.2. Investigated Scenarios

In order to predict the effects of introducing energy storage systems on the network stability of the distribution network of Cyprus, especially overvoltage effects, and to compare them in terms of cost with a traditional solution in the local network infrastructure, four scenarios have been investigated using the PLATOS software tool. These scenarios are (a) Scenario 1, the use of one storage unit to overcome overvoltage problem in the nodes of the LV distribution feeder, (b) Scenario 2, the use of two storage units to overcome overvoltage problem in the nodes of the LV distribution feeder, (c) Scenario 3, the use of three storage units to overcome overvoltage problem in the nodes of the LV distribution feeder and (d) Scenario 4, the use of extra power connection between the node LV PILLAR and node J6 as an alternative solution to solve overvoltage problem in the nodes of the LV distribution feeder.

## 4.3. Input Data in PLATOS Software Tool

For all the above scenarios the network topology of the case study for the LV distribution network of Cyprus with the component data, the load and the generation patterns of each node have been inserted into the PLATOS software tool. Also, the software takes into account an undervoltage limit of 0.94 p.u. or 0.376 kV, an overvoltage limit of 1.06 p.u. or 0.424 kV, an overloading limit of 100% and maximum depth of the voltage dips to be alleviated 0.1 p.u. Furthermore, 10 types of storage units with discharging and charging power and 10 sizes of storage units between 2 kWh up to 60 kWh, as shown in Table 1, have been used for the simulations.

**Table 1. Types and sizes of storage units.**

| No. | Charging Power of Storage Unit (kW) | Discharging Power of Storage Unit (kW) | Sizes of Storage Units (kWh) |
|-----|-------------------------------------|--|------------------------------|
| 1   | -2                                  | 2                                      | 2                            |
| 2   | -4                                  | 4                                      | 4                            |
| 3   | -6                                  | 6                                      | 6                            |
| 4   | -8                                  | 8                                      | 8                            |
| 5   | -10                                 | 10                                     | 10                           |
| 6   | -20                                 | 20                                     | 20                           |
| 7   | -30                                 | 30                                     | 30                           |
| 8   | -40                                 | 40                                     | 40                           |
| 9   | -50                                 | 50                                     | 50                           |
| 10  | -60                                 | 60                                     | 60                           |

For the first three scenarios, a Lithium-Ion (Li-Ion) battery has been used with relative installation cost of 1204.1 €/kWh and average maximum active power increment 10%/min [3]. Effects such as repeated charge/discharge cycles, (which can shorten the lifetime of the battery system as well as the quality of the battery due to degradation) and the lifetime of Li-Ion batteries (which is temperature dependant with aging taking its toll much faster at high temperatures, and can be severely shortened due to deep discharges) have also be taken into account. For the fourth scenario, a typical cable with relative cost of 39000 €/km and a length of connection 0.331 km has

been used.

## 5. Discussion

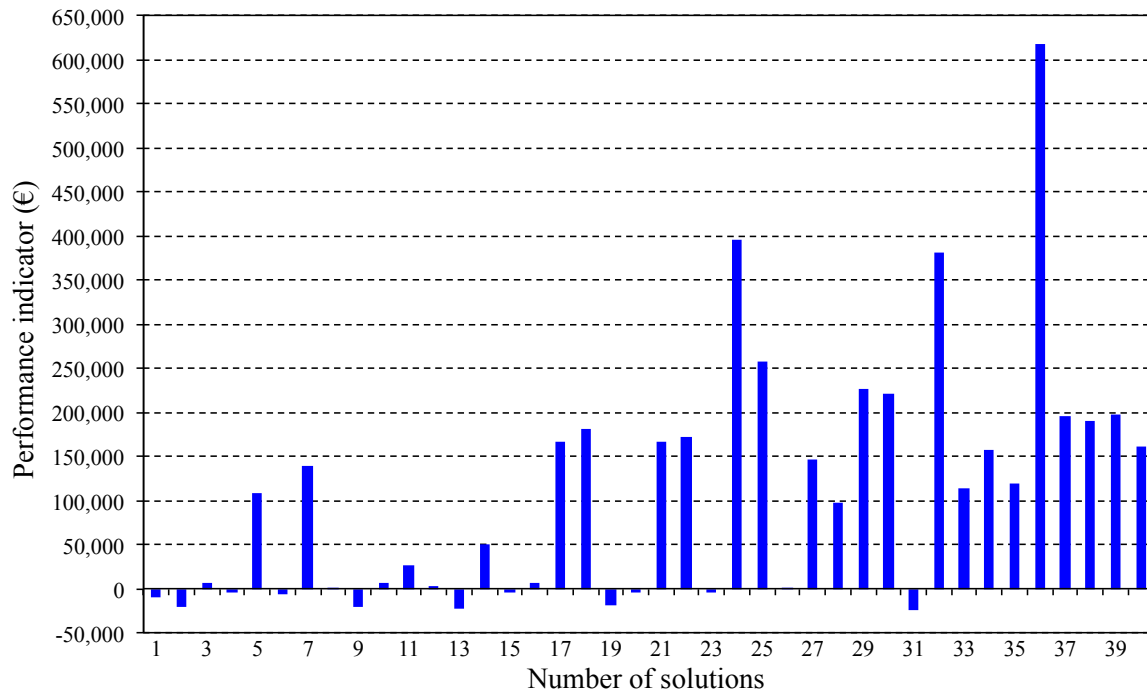
For all scenarios investigated, overvoltage occurs between 11:00 and 14:30 hour, as shown in Table 2. The problem is identified in one node from 11:00–12:00 hour, in four nodes from 12:00–13:00 hour, in five nodes from 13:00–14:00 hour and in 2 nodes from 14:00–15:00 hour.

**Table 2. LV virtual distribution feeder overvoltage problems.**

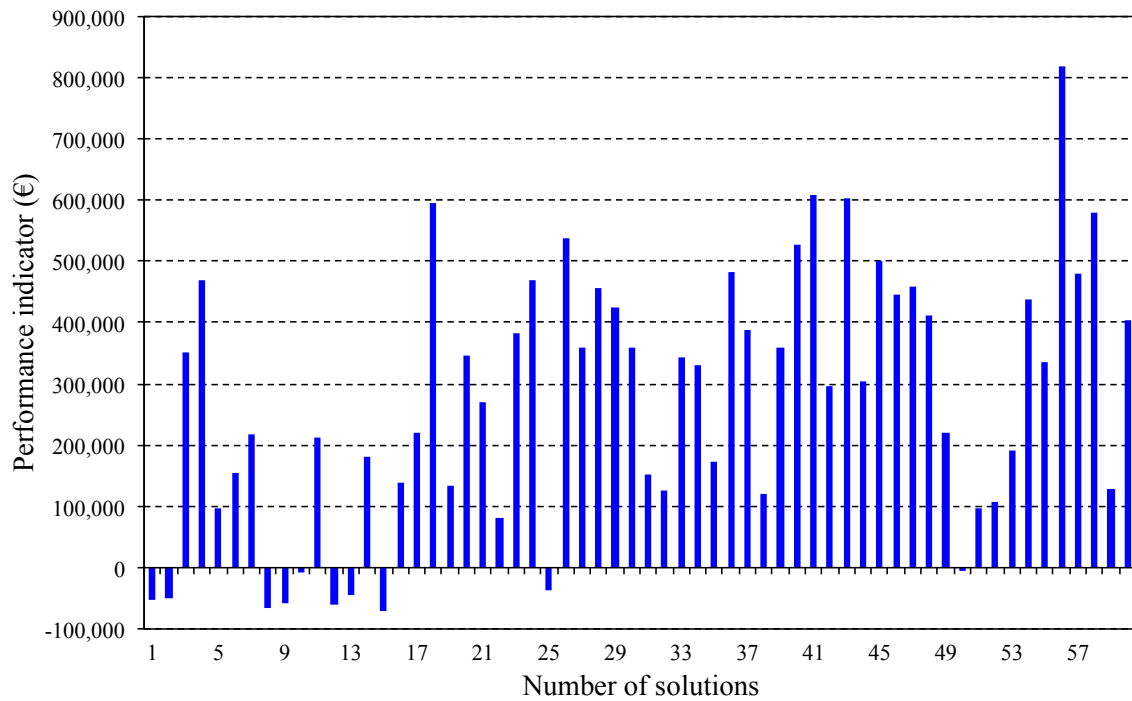
| Time  | Node with Lowest Voltage | Lowest Voltage (kV) | Node with Highest Voltage | Highest Voltage (kV) | Number of Nodes with Overvoltage |
|-------|--------------------------|---------------------|---------------------------|----------------------|----------------------------------|
| 10:00 | J6                       | 0.4088              | J6                        | 0.4237               | 0                                |
| 10:30 | J6                       | 0.4088              | J6                        | 0.4237               | 0                                |
| 11:00 | J6                       | 0.4088              | J6                        | 0.4241               | 1                                |
| 11:30 | J6                       | 0.4088              | J6                        | 0.4241               | 1                                |
| 12:00 | J6                       | 0.4088              | J6                        | 0.4267               | 4                                |
| 12:30 | J6                       | 0.4088              | J6                        | 0.4267               | 4                                |
| 13:00 | J6                       | 0.4088              | J6                        | 0.4274               | 5                                |
| 13:30 | J6                       | 0.4088              | J6                        | 0.4274               | 5                                |
| 14:00 | J6                       | 0.4088              | J6                        | 0.4274               | 2                                |
| 14:30 | J6                       | 0.4088              | J6                        | 0.4274               | 2                                |
| 15:00 | J6                       | 0.4088              | J6                        | 0.4274               | 0                                |
| 15:30 | J6                       | 0.4088              | J6                        | 0.4274               | 0                                |
| 16:00 | J6                       | 0.4088              | J6                        | 0.4274               | 0                                |
| 16:30 | J6                       | 0.4088              | J6                        | 0.4274               | 0                                |
| 17:00 | J6                       | 0.4088              | J6                        | 0.4274               | 0                                |
| 17:30 | J6                       | 0.4088              | J6                        | 0.4274               | 0                                |
| 18:00 | J6                       | 0.4088              | J6                        | 0.4274               | 0                                |
| 18:30 | J6                       | 0.4088              | J6                        | 0.4274               | 0                                |
| 19:00 | J6                       | 0.4074              | J6                        | 0.4274               | 0                                |
| 19:30 | J6                       | 0.4074              | J6                        | 0.4274               | 0                                |
| 20:00 | J6                       | 0.3959              | J6                        | 0.4274               | 0                                |
| 20:30 | J6                       | 0.3959              | J6                        | 0.4274               | 0                                |
| 21:00 | J6                       | 0.3959              | J6                        | 0.4274               | 0                                |
| 21:30 | J6                       | 0.3959              | J6                        | 0.4274               | 0                                |
| 22:00 | J6                       | 0.3959              | J6                        | 0.4274               | 0                                |
| 22:30 | J6                       | 0.3959              | J6                        | 0.4274               | 0                                |
| 23:00 | J6                       | 0.3959              | J6                        | 0.4274               | 0                                |
| 23:30 | J6                       | 0.3959              | J6                        | 0.4274               | 0                                |

For the first three scenarios, 4 generations with 20 genes each are being used, accounting for 80 possible solutions (called nucleotides). In order that the simulations converge to an optimum solution, a minimum performance objective boundary has been used, which was €350,000 for the first

scenario, €600,000 for the second scenario and €800,000 for the third scenario with a performance convergence objective of 0.01%.

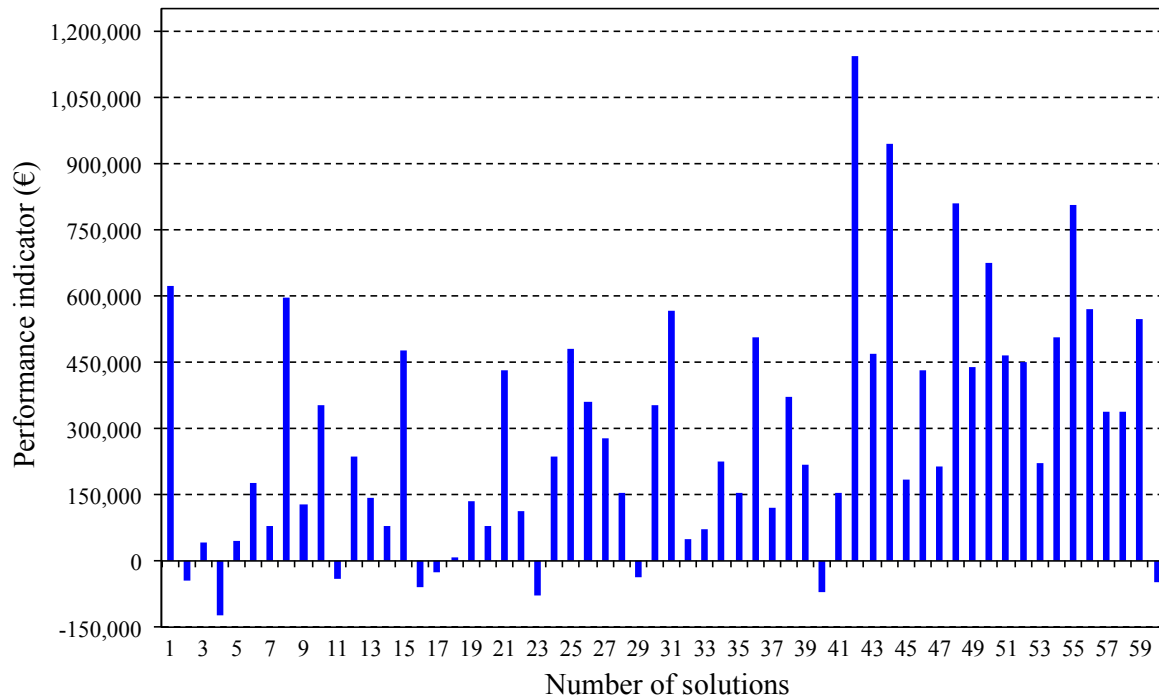


**Figure 9. Solutions for scenario 1.**



**Figure 10. Solutions for scenario 2.**

For the first scenario, only 40 solutions were needed by PLATOS to find the optimum solution which was solution number 36, as illustrated in Figure 9, whereas for the second scenario and the third scenario, 60 solutions were needed and the optimum solutions were solution number 56 and solution number 42 respectively, as illustrated in Figure 10 and Figure 11. It can be observed that for some solutions the performance indicator is negative, which means that for these solutions the storage system, although it solves the problem of overvoltage, is not economically viable.



**Figure 11. Solutions for scenario 3.**

Table 3 gives an overview of the solutions for the first scenario, regarding the position node of the LV distribution feeder of Cyprus, illustrated in Figure 4, where the storage unit will be installed to solve the overvoltage problem, the type of the storage unit that will be installed, with the relative charging and discharging power, the size of the storage unit that will be installed, the performance indicator (NPV value in €), and the payback period.

It can be observed that the optimum solution for the first scenario, which as mentioned above is solution number 36, concerns the installation of a storage unit with charging power  $-8$  kW, discharging power  $8$  kW and size of  $50$  kWh at node J5. This solution has a performance indicator of  $\text{€}617,566$  and payback period of one year. Also, the performance indicator of a solution depends on the type, the size and the position where the storage unit will be installed. In addition, some solutions, although they provide a technical solution for the overvoltage problem, economically are not viable since the performance indicator is negative with payback period of 100 years. For these cases an additional penalty of  $\text{€}4000$  is included in the performance indicator, because of the no viability.

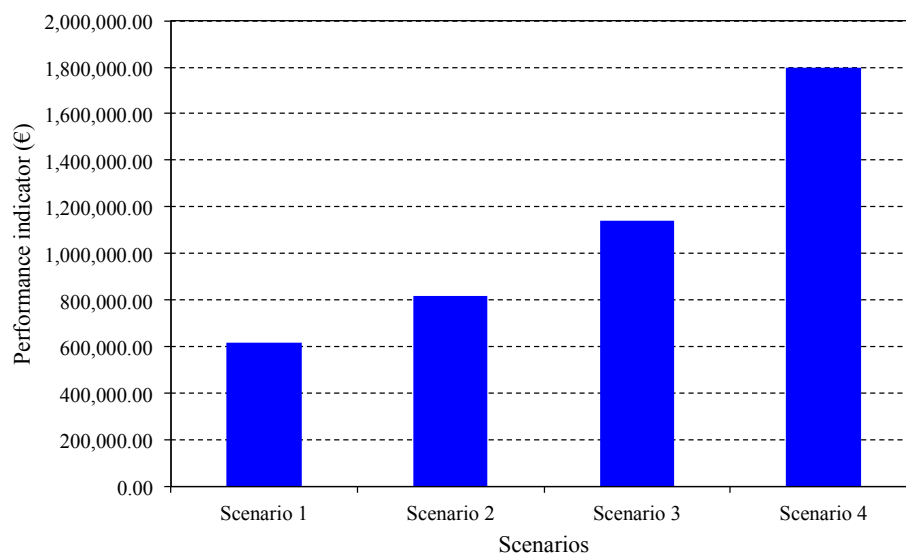
**Table 3. Overview of solutions of Scenario 1.**

| Solution Number | Storage Unit Location Node | Type of Storage Unit                |  | Size of Storage Unit (kWh) | Performance Indicator (€) | Payback Period (Years) |
|-----------------|----------------------------|-------------------------------------|--|----------------------------|---------------------------|------------------------|
|                 |                            | Charging Power of Storage Unit (kW) | Discharging Power of Storage Unit (kW) |                            |                           |                        |
| 1               | J1                         | -50                                 | 50                                     | 6                          | -8894                     | 100                    |
| 2               | J5                         | -50                                 | 50                                     | 20                         | -21431                    | 100                    |
| 3               | J5                         | -8                                  | 8                                      | 2                          | 6977                      | 4                      |
| 4               | J5                         | -10                                 | 10                                     | 10                         | -4538                     | 100                    |
| 5               | J2                         | -2                                  | 2                                      | 50                         | 108896                    | 4                      |
| 6               | J1                         | -30                                 | 30                                     | 8                          | -6763                     | 100                    |
| 7               | J3                         | -10                                 | 10                                     | 40                         | 138504                    | 3                      |
| 8               | J2                         | -40                                 | 40                                     | 2                          | 574                       | 14                     |
| 9               | J6                         | -50                                 | 50                                     | 20                         | -21430                    | 100                    |
| 10              | J6                         | -6                                  | 6                                      | 4                          | 5599                      | 6                      |
| 11              | J2                         | -2                                  | 2                                      | 6                          | 25706                     | 3                      |
| 12              | J4                         | -6                                  | 6                                      | 8                          | 2041                      | 12                     |
| 13              | J6                         | -60                                 | 60                                     | 20                         | -23430                    | 100                    |
| 14              | J4                         | -2                                  | 2                                      | 8                          | 50567                     | 2                      |
| 15              | J3                         | -20                                 | 20                                     | 8                          | -4761                     | 100                    |
| 16              | J5                         | -4                                  | 4                                      | 4                          | 5998                      | 6                      |
| 17              | J4                         | -8                                  | 8                                      | 20                         | 166931                    | 2                      |
| 18              | J6                         | -8                                  | 8                                      | 30                         | 181827                    | 2                      |
| 19              | J6                         | -40                                 | 40                                     | 20                         | -19430                    | 100                    |
| 20              | J1                         | -8                                  | 8                                      | 10                         | -4141                     | 100                    |
| 21              | J4                         | -8                                  | 8                                      | 20                         | 166931                    | 2                      |
| 22              | J5                         | -8                                  | 8                                      | 30                         | 172552                    | 2                      |
| 23              | J5                         | -8                                  | 8                                      | 10                         | -4138                     | 100                    |
| 24              | J5                         | -8                                  | 8                                      | 40                         | 395059                    | 1                      |
| 25              | J2                         | -10                                 | 10                                     | 50                         | 258149                    | 2                      |
| 26              | J1                         | -4                                  | 4                                      | 4                          | 171                       | 15                     |
| 27              | J3                         | -10                                 | 10                                     | 30                         | 147397                    | 2                      |
| 28              | J2                         | -10                                 | 10                                     | 40                         | 97315                     | 4                      |
| 29              | J6                         | -10                                 | 10                                     | 30                         | 225835                    | 2                      |
| 30              | J6                         | -2                                  | 2                                      | 30                         | 220401                    | 2                      |
| 31              | J2                         | -20                                 | 20                                     | 30                         | -24326                    | 100                    |
| 32              | J4                         | -4                                  | 4                                      | 50                         | 380763                    | 2                      |
| 33              | J6                         | -2                                  | 2                                      | 10                         | 114512                    | 1                      |
| 34              | J4                         | -8                                  | 8                                      | 30                         | 158038                    | 2                      |
| 35              | J3                         | -8                                  | 8                                      | 30                         | 119126                    | 3                      |
| 36              | J5                         | -8                                  | 8                                      | 50                         | 617566                    | 1                      |
| 37              | J4                         | -10                                 | 10                                     | 30                         | 196063                    | 2                      |
| 38              | J6                         | -8                                  | 8                                      | 20                         | 190720                    | 2                      |
| 39              | J6                         | -2                                  | 2                                      | 20                         | 197401                    | 1                      |
| 40              | J1                         | -8                                  | 8                                      | 50                         | 161666                    | 3                      |

For the second scenario, the optimum solution is solution number 56, which concerns the installation of two storage units with charging power -8 kW and -2 kW, discharging power 8 kW and 2 kW, sizes of 50 kWh and 30 kWh, respectively, at node J5 the first storage unit and at node J6 the second storage unit. The performance indicator of this solution is €818,828 with payback period of 1 year. For the third scenario, the optimum solution is number 42, which concerns the installation of three storage units with charging power -6 kW, -6 kW and -4 kW, discharging power 6 kW, 6 kW

and 4 kW, sizes of 30 kWh, 50 kWh and 60 kWh, respectively, at node J5 the first storage unit, at node J6 the second storage unit and at node J4 the third storage unit. This solution has a performance indicator of €1,142,776 and payback period of 2 years. Concerning the fourth scenario, which concerns an alternative solution to the problem of the overvoltage in the virtual LV distribution feeder of Cyprus by the installation of extra power connection between the node LV PILLAR with the node J6, the performance indicator is €1,799,209 and the payback period is one year.

The performance indicator of the optimum solution of each scenario is compared to the performance indicator of the alternative solution and illustrated in Figure 12. It can be observed that for solving the problem of overvoltage of the LV distribution feeder of Cyprus, as more storage units are installed the better the performance indicator and, therefore, the more attractive is the investment in storage units to solve power quality problems in the distribution network. In the case where the technical requirements in voltage limitations according to distribution regulations are satisfied with one storage unit, the installation of an additional storage unit will only increase the final cost. The best solution, however, still remains the alternative solution of connecting an extra cable between the node with the lowest voltage and the node with the highest voltage of the distribution network, due to the lower investment costs compared to that of the storage units.



**Figure 12. Comparison of the performance indicator for the scenarios examined.**

## 6. Conclusions

In this work, the structure of the Cyprus distribution network was described and the PLATOS software tool, developed within the framework of GROW-DERS, was presented. In order to investigate the possible overvoltage effects in the distribution network of Cyprus, on both technical and economical point of view, several scenarios of storage units' installation were used and compared with the alternative solution of extra cable connection between the node with the lowest voltage and the node with the highest voltage of the distribution network. For the comparison, a case study of a typical LV distribution feeder of Cyprus was used.

The performance indicator of a solution, expressed as the NPV, depends on the type, the size and the position where the storage unit will be installed. In addition, some solutions, although provide a technical solution for the overvoltage problem, are not economically viable since the performance indicator is negative and the payback period is 100 years.

The results indicated that for overcoming the problem of overvoltage of the LV distribution feeder of Cyprus, as more storage units are installed the better the performance indicator and, therefore, the more attractive is the investment in storage units to solve power quality problems in the distribution network. In the case where the technical requirements in voltage limitations according to distribution regulations are satisfied with one storage unit, the installation of an additional storage unit will only increase the final cost. The best solution, however, still remains the alternative solution of connecting an extra cable, due to the lower investment costs compared to that of the storage units.

Other storage solutions could also be investigated for the possibility of offering a more economical alternative to the overvoltage problem for small-scale power applications compared to the Li-Ion battery system. Such solutions could be a flywheel system, or other types of battery storage such as lead-acid, nickel based batteries or flow type batteries. Detailed description of such alternative storage systems can be found in [15] and [16].

## Acknowledgments

This work has been partially funded by the by the Sixth Framework Program of Research and Development of the European Union, Contract No: SES6-CT-2007-038665. Also, the authors gratefully acknowledge the contributions of Petra de Boer, Gabriel Bloehof, Roger Cremers, and Herve Colin for their work on the validation of the PLATOS software for the Cyprus case study.

## Conflict of Interest

All authors declare no conflicts of interest in this paper.

## References

1. European Commission: Directive 2009/28/EC of the European Parliament and of the Council 23 April 2009 on the promotion of the use of energy from renewable sources and amending and subsequently repealing Directives 2001/77/EC and 2003/30/EC, 2009. Available from: [http://ec.europa.eu/index\\_en.htm](http://ec.europa.eu/index_en.htm).
2. Poullikkas A., Kourtis G., Hadjipaschalis I. (2011) A hybrid model for the optimum integration of renewable technologies in power generation systems. *Energ Policy* 39: 926–935.
3. Noroozian R., Abedi M., Gharehpetian G.B., Hosseini S.H. (2010) Distributed resources and DC distribution system combination for high power quality. *Int J Elec Power* 32: 769–781.
4. Koochi-Kamali S., Tyagi V.V., Rahim N.A., Panwar N.L., Mokhlis H. (2013) Emergence of energy storage technologies as the solution for reliable operation of smart power systems: A review. *Renew Sust Energ Rev* 25: 135–165.

5. Schreurs M., De Boer P., Hooiveld R. (2010) GROW-DERS; Grid reliability and operability with distributed generation using flexible storage. *In proceeding of China International Conference on Electricity Distribution*.
6. Arghandeh R., Onen A., Jung J., Broadwater R.P. (2013) Harmonic interactions of multiple distributed energy resources in power distribution networks. *Electr Pow Syst Res* 105: 124–133.
7. Khalid M., Savkin A.V. (2014) Minimization and control of battery energy storage for wind power smoothing: Aggregated, distributed and semi-distributed storage. *Renew Energ* 64: 105–112.
8. Cyprus Transmission System Operator: Transmission and Distribution Rules, 2011. Available from: [http://www.dsm.org.cy/nqcontent.cfm?a\\_id=1&lang=12](http://www.dsm.org.cy/nqcontent.cfm?a_id=1&lang=12)
9. The GROW-DERS project. Available from: <http://growders.eu/>
10. Kashem M.A., Ledwich G. (2007) Energy requirement for distributed energy resources with battery energy storage for voltage support in three-phase distribution lines. *Electr Pow Syst Res* 77: 10–23.
11. Farhoodnea M., Mohamed A., Shareef H., Zayandehroodi H. (2013) Power quality impacts of high-penetration electric vehicle stations and renewable energy-based generators on power distribution systems. *Measurement* 46: 2423–2434.
12. PowerFactory: User's Manual DIgSILENT PowerFactory Version 14.0. Available from : <http://www.digsilent.de/index.php/products-powerfactory.html>
13. De Boer P., Gütschow D., Cremers R. (2010) GROW-DERS; Grid reliability and operability with distributed generation using flexible storage, *presented at the CIRED Workshop*, Lyon, France.
14. Kamatchi Kannan V., Rengarajan N. (2012) Photovoltaic based distribution static compensator for power quality improvement. *Int J Elec Power* 42: 685–692.
15. Hadjipaschalis I., Poullikkas A., Efthimiou V. (2009) Overview of current and future energy storage technologies for electric power applications. *Renew Sust Energ Rev* 13: 1513–1522.
16. Poullikkas A. (2013) A comparative overview of large-scale battery systems for electricity storage. *Renew Sust Energ Rev* 27: 778–788.

© 2014, Andreas Poullikkas, licensee AIMS. This is an open access article distributed under the terms of the Creative Commons Attribution License (<http://creativecommons.org/licenses/by/3.0>)